



S110S

110 Ah | 12 V | 20 h

Specifications

Voltage	12 V
Nominal Capacity	110 Ah @ 20 hour-rate
Number of Cells	6
Internal Resistance	Approx. 6.5 mΩ
Design Life	12 years (float charging)
Short Circuit Current	2200 A
Self Discharge	Monthly rate < 3% @ 25 °C Recharge after 6 months Charge before using

Charging & Discharging

Max. Charging Current	30.0 A
Max. Discharge Current	1000 A (5 sec)
Standby Use Voltage	13.6 V to 13.8 V @ 25 °C Temperature Compensation: -3mV/°C/Cell
Cycle Use Voltage	14.6 V to 14.8 V @ 25 °C Temperature Compensation: -4mV/°C/Cell
Reference Capacity	C3 77 Ah C5 87 Ah C10 100 Ah C20 110 Ah

Temperature Ranges

Normal Operation	25 °C ± 5 °C
Discharging	-20 °C to 60 °C
Charging	0 °C to 50 °C
Storage	-20 °C to 60 °C

Mechanical Specifications

Measurements (L x W x H)	306 x 168 x 210 mm
Weight	Approx. 26.0 kg
Terminals	F15(M6)
Case material	A.B.S. UL94-HB, UL94-V0 Optional

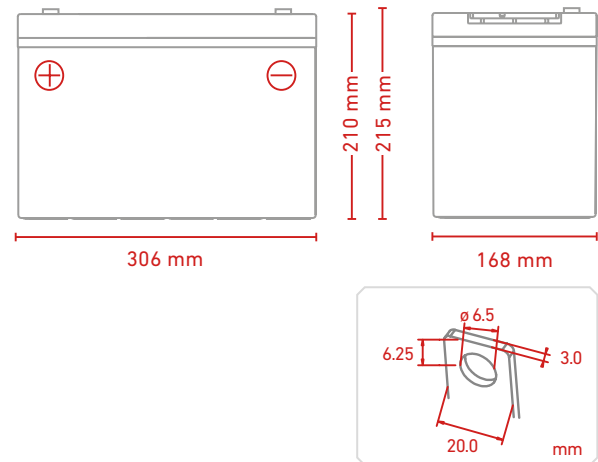

Discharge Characteristics Curve

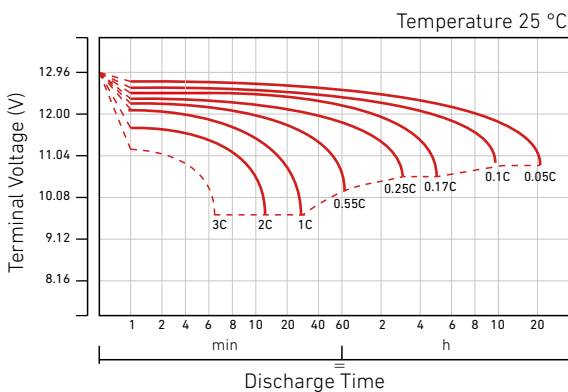

Cycle Life in Relation to Depth of Discharge

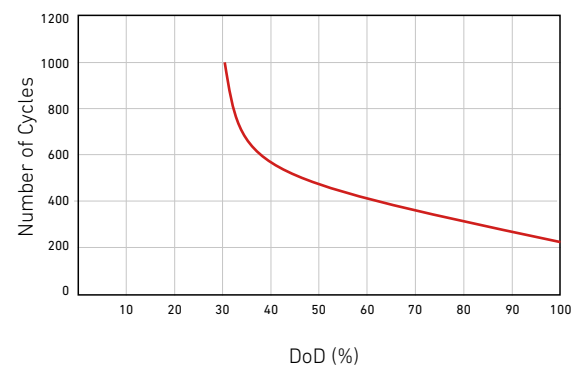

Discharge Characteristics Curve For Standby Use

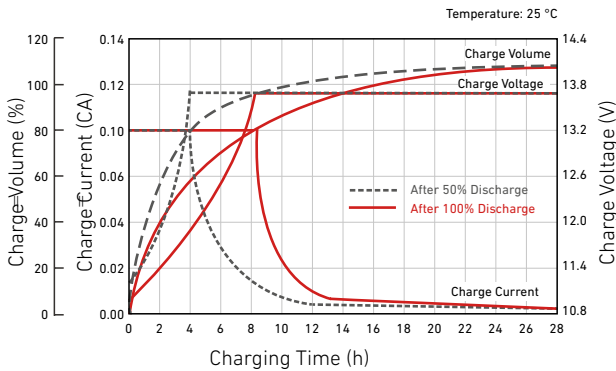

Relationship Between Charging Voltage and Temperature

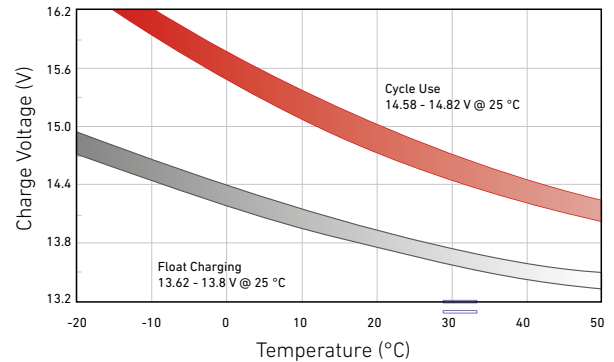

Temperature Effects on Capacity

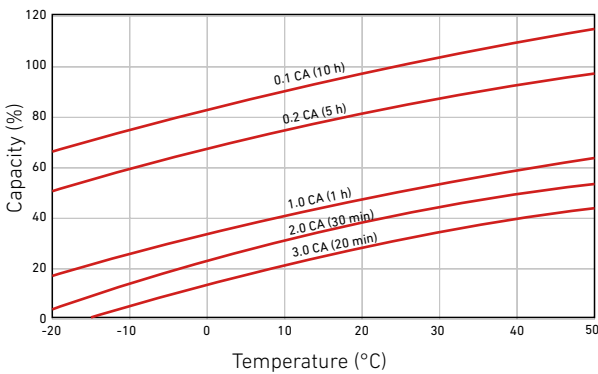

Storage Characteristics

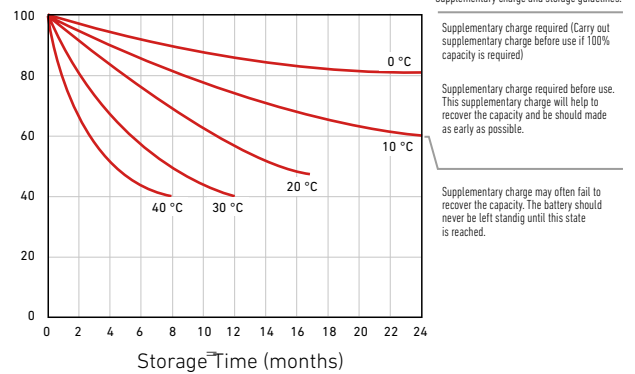

Effect of Temperature on Long-Term Life

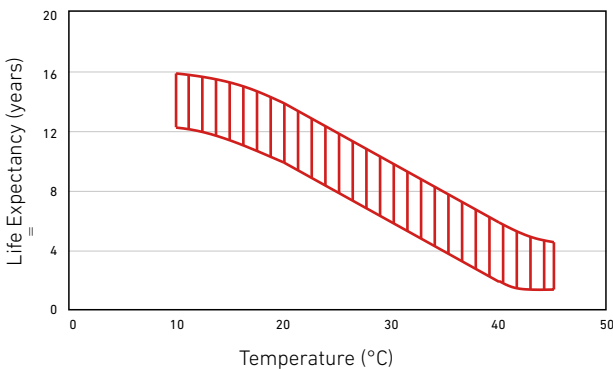

Life Characteristics of Standby Use

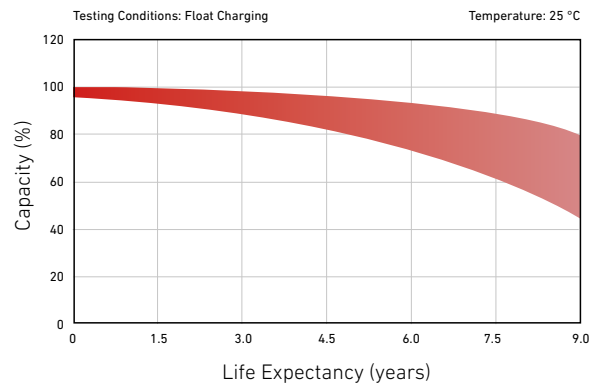

Constant Current Discharge Characteristics: A (25 °C)

	Time										
	10 min	15 min	30 min	1 h	2 h	3 h	4 h	5 h	8 h	10 h	20 h
1.60 V	216,0	172,7	104,1	61,1	36,4	28,2	22,2	18,9	12,7	10,5	5,52
1.65 V	193,3	165,1	100,0	59,0	35,2	27,3	21,6	18,4	12,5	10,4	5,43
1.70 V	178,0	154,6	95,5	57,1	34,1	26,6	21,0	17,9	12,3	10,3	5,36
1.75 V	162,9	143,9	91,3	55,0	32,9	25,8	20,4	17,4	12,2	10,1	5,30
1.80 V	147,4	132,9	87,3	52,9	31,7	25,0	19,9	17,0	12,0	10,0	5,25
1.85 V	120,5	110,3	75,2	47,4	29,1	23,1	18,5	15,9	11,2	9,4	4,98

Constant Power Discharge Characteristics: WPC (25 °C)

	Time										
	10 min	15 min	30 min	1 h	2 h	3 h	4 h	5 h	8 h	10 h	20 h
1.60 V	347,7	314,5	193,0	113,7	68,3	53,3	42,1	36,0	24,5	20,5	10,76
1.65 V	334,9	305,1	187,2	110,4	66,4	51,9	41,1	35,2	24,3	20,3	10,60
1.70 V	314,0	290,1	180,8	107,5	64,6	50,7	40,2	34,4	24,0	20,0	10,49
1.75 V	292,6	273,8	174,5	104,2	62,6	49,4	39,3	33,7	23,7	19,8	10,37
1.80 V	269,5	256,4	168,5	100,8	60,7	48,1	38,3	32,9	23,3	19,6	10,28
1.85 V	224,1	215,8	146,6	90,9	55,9	44,6	35,7	30,8	22,0	18,4	9,78